

only nature moves fluid more efficiently.

SCC DC-4A / DC-4TAT SUBMERSIBLE 12V DC CENTRIFUGAL PUMPS

Used for RV and Marine applications; ideal for use in boats, trailers, and other applications

These small, compact centrifugal pumps are operated by a 12-volt DC motor and are used primarily for RV and Marine applications. The units have a high flow rate with low pressure, and can be used for bilge as well as de-watering. Ideal for use in boats, trailers, or other areas where electricity is not available. Operable with standard car, tractor, and/or marine battery or where any 12-volt DC current is available. Pumps can be used in either submersible or open air applications, depending on model.

Pumps are available with a threaded discharge connection (DC-4), or a barbed discharge connection (DC-4B) for quick installation. Each pump comes equipped with two suction heads, a screened submersible suction head, or a threaded male suction port, for adaptation to fit user's needs

Constructed of high-impact-resistant FDA grade Ultraform plastic with a stainless steel motor shaft. Stainless fasteners also help make these pumps corrosion resistant. Units come equipped with 6 ft. wire leads and has ¼" mounting slots in footings for easy installation.

Pumps have very low AMP draw (less than 2 amps), and have an open impeller to help with dirty or contaminated solutions. Designed for intermittent duty only. The brush-type motor provides high speed operation. **ALSO AVAILABLE IN 24v DC.**

Description	DC-4A, DC-4B
Power supply required	12V DC
Motor, full load Amps (fuse size)	2.0 Amps
Motor type	PM
Pump leads & length	18 Ga. 56" 2 leads (red = +, black = -)
Dimensions	2-1/8" x 2-1/8" x 5-1/4"
Max. liquid temperature	+ 160° F
Minimum temperature	+ 40° F
Pump material	FDA grade Ultraform Pump head; ABS-Motor housing
Motor shaft material	416 S.S.
Ports: (Discharge DC-4A)	3/8" NPT
(Discharge DC-4B)	3/8" Barbed
(Suction DC-4A, DC-4TAT)	Screened or 1/2" MPT
Gasket	Nitrile™
Shaft seal	Nitrile™
"O" rings	Neoprene
Hardware	18-8 S.S.
Shipping weight	14 oz.

Note: Specifications subject to change without notice.

DC-4TAT SUBMERSIBLE

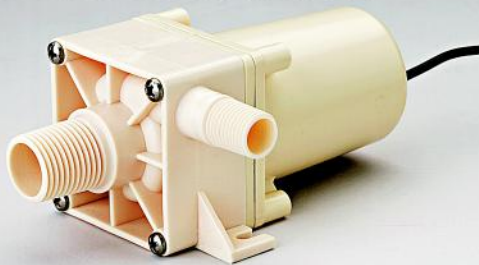

DC-4A SUBMERSIBLE

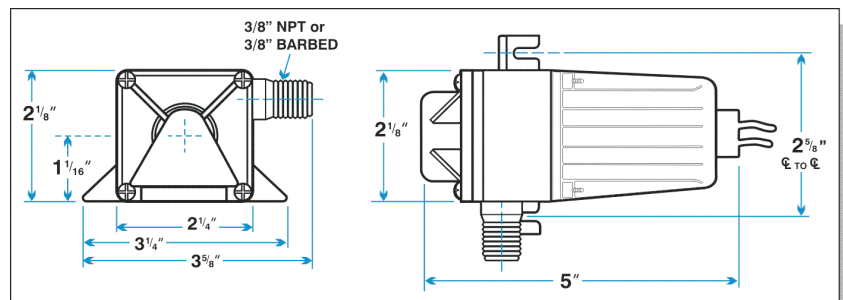

MODEL / FT.	1'	3'	5'	7'	9'	11'	Shut-Off
Threaded-Inlet	410	390	330	250	175	100	15.2 FT.
Screened-Inlet	340	300	250	190	110	40	12 FT.

DC-4 / DC-4TAT Performances

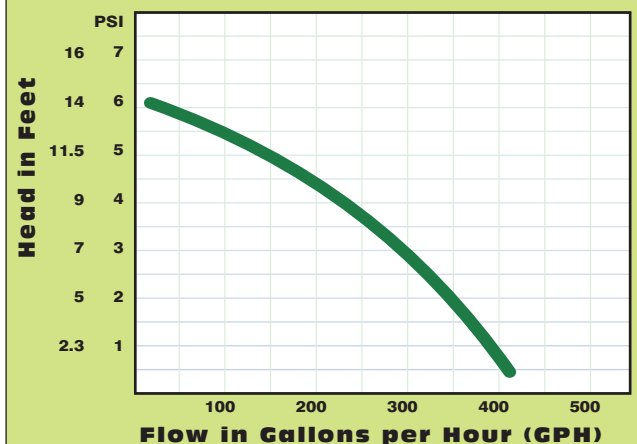

SCC PUMPS, INC.

THE SMALL PUMP SPECIALISTS

General Offices:

708 W. Algonquin Road; Arlington Heights, IL 60005
info@sccpumps.com ☎ www.sccpumps.com

Manufacturing: P: 847-593-8495, or 800-334-1199 ☎ F: 847-593-8204

Distribution: Midwest: 847-593-8201 ☎ F: 847-593-8204